



CAA Presentation

Exoplanet Direct Imaging: Coronagraph Probe Mission Study (Exo-C)

March 4 2014

Karl Stapelfeldt
NASA Goddard
Space Flight Center
Michael Brenner
Jet Propulsion Laboratory,
California Institute of Technology

For the Exo-C STDT
and Design Team

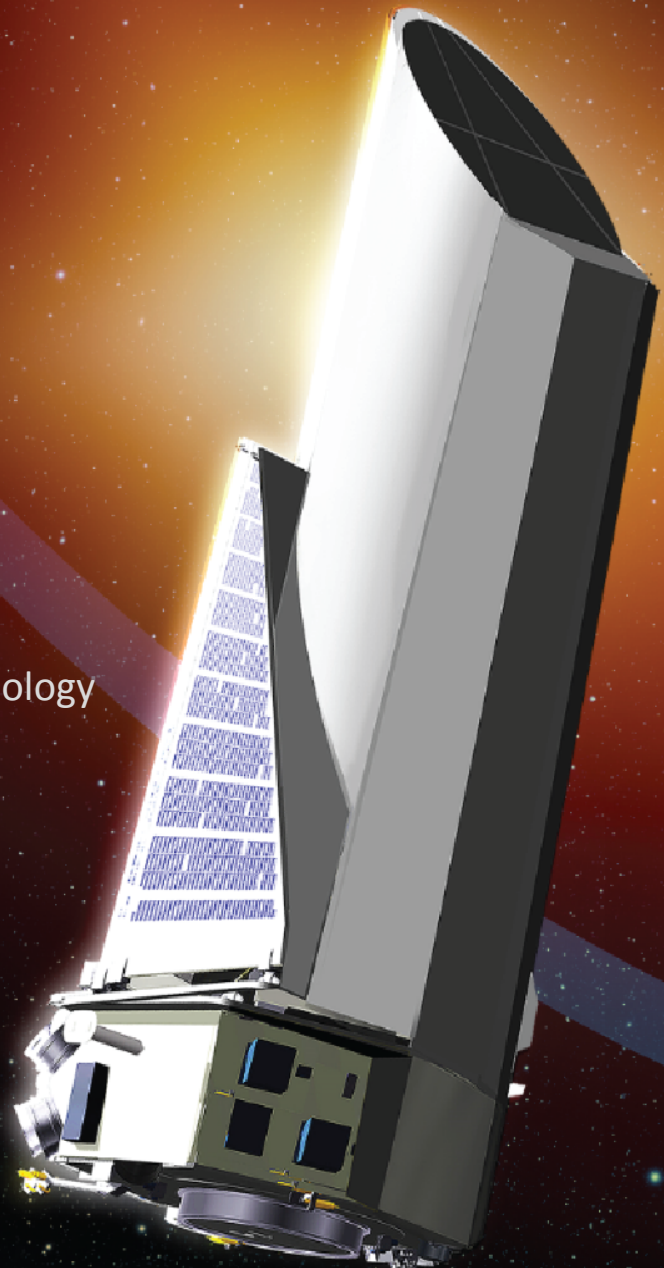
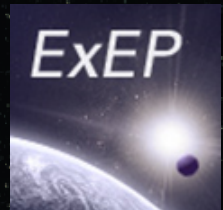



Exo-C Key People



Science and Technology Definition Team

- Karl Stapelfeldt (Chair, GSFC)
- Rus Belikov (NASA/Ames)
- Geoff Bryden (JPL/Caltech)
- Kerri Cahoy (MIT)
- Supriya Chakrabarti (UMass Lowell)
- Mark Marley (NASA/Ames)
- Michael McElwain (NASA/GSFC)
- Vikki Meadows (U. Washington)
- Gene Serabyn (JPL/Caltech)
- John Trauger (JPL/Caltech)

JPL Engineering Design Team

- Keith Warfield
- Paul Brugarolas
- Frank Dekens
- Serge Dubovitsky
- Bobby Effinger
- Brian Hirsch
- Andy Kissil
- Michael Brenner
- John Krist
- Jared Lang
- Joel Nissen
- Jeff Oseas
- Eric Sunada

ExEP Office

- Gary Blackwood
- Peter Lawson
- Wes Traub
- Steve Unwin



Context for Exo-C Study



- Flagship mission for spectroscopy of ExoEarths requires 10^{-10} contrast ($> 10,000$ times beyond HST performance) and aperture size > 4 m. A big step financially and technologically.
- A smaller mission for spectroscopy of giant exoplanets and imaging of disks requires 10^{-9} broadband contrast (already demonstrated in lab) and ~ 1.5 m telescope. More affordable, intermediate technology step. *Concept endorsed by Astro2010 EOS panel*
- There is a rich heritage for the concept: proposed by various PIs a dozen times since 1999, but there was no programmatic niche for it
- Kepler finds that mini-Neptunes are very common, but the nature of their atmospheres is a mystery. New characterization opportunity for a probe-scale mission.



Exoplanet Probes Linkage to Astro 2010



“The (EOS) panel did evaluate, and found appealing, several “probe-class” concepts employing ~1.5-m primary mirrors and internal star-light suppression systems, often coronagraphs with advanced wavefront control. Each was judged to be technically feasible after completion of a several year technology development program, and could cost significantly less than a precision astrometry mission like SIM Lite. Such a mission could image about a dozen known (RV) giant planets and search hundreds of other nearby stars for giant planets. Importantly, it could also measure the distribution and amount of exozodiacal disk emission to levels below that in our own solar system (1 zodi) and detect super-Earth planets in the habitable zones of up to two dozen nearby stars. These would be extremely important steps, both technically and scientifically, toward a mission that could find and characterize an Earth-twin.”

NOW GOING IN PAUL HERTZ'S PRESENTATION

Science frontier discovery areas:

- Identification and characterization of nearby habitable exoplanets
- How diverse are planetary systems ?
- How do circumstellar disks evolve and form planetary systems ?

“... a critical element of the committee’s exoplanet strategy is to continue to build the inventory of planetary systems around specific nearby stars”

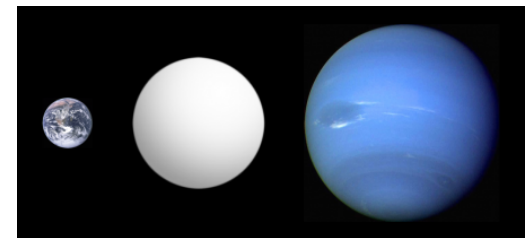



Exoplanet Science in 2024



- Indirect detections: RV surveys have detected long period planets \geq Saturn mass, 1 AU planets down to Neptune mass. GAIA detects short-period Jupiters. Target lists for spectra.
- Transits: TESS has extended Kepler results to brighter stars, defining planet mass-radius relationship. JWST+ELTs get transmission spectra for some of these. Target list for outer planet imaging searches.
- Exoplanet Direct Imaging: Ground AO has obtained spectra of dozens of young/massive planets in near-IR thermal emission. Likely contrast limit of $\sim 10^{-8}$ set by atmospheric turbulence. JWST images cold/wide giant planets around M stars (contrast $\sim 10^{-6}$).
- Disk Imaging: ALMA redefines knowledge of protoplanetary disks, but cannot map tenuous debris disks at subarcsec resolution. Ground AO imaging polarimetry of brighter disks.

- Obtain optical spectra of nearest RV planets:
Measure gas absorbers, fix planet mass.
- Search for planets beyond RV limits (Neptunes, super-Earths) in a nearby star sample. Measure orbits, do spectroscopy of the brightest ones
 - alpha Centauri system is a very important case
- Image circumstellar disks beyond HST, AO, and ALMA limits
 - Resolve structures driven by planetary perturbations, including in nearest habitable zones
 - Time evolution of disk structure & dust properties from protoplanetary to debris disks
- Probe a few systems for exo-Earths, if telescope stability and exozodi are favorable

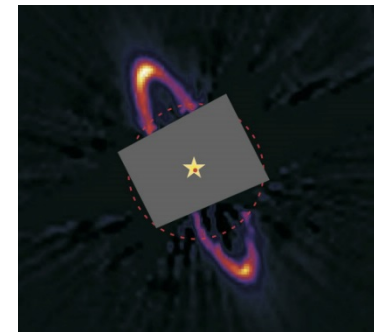
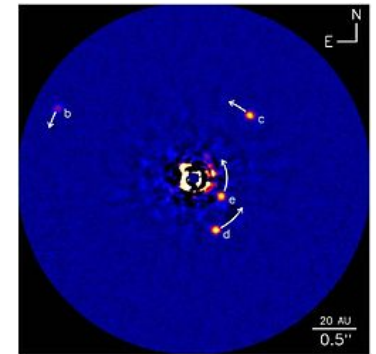
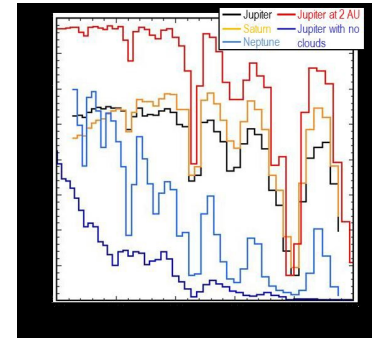



Current Working Science Requirements



Primary diameter	> 1.3 m
Uncontrolled speckle contrast	1e-09 raw
Contrast stability over 48 hours	1e-10; defines faintest detections
Spectral coverage	450–1000 nm
Inner Working Angle $2 \lambda/D$	0.22 arcsec @ 800 nm
Outer Working Angle $> 20 \lambda/D$	> 2 arcsec @ 800 nm
Spillover light from binary companion	$\leq 1e-9$ @ 8 arcsec
Spectral resolution $\lambda < 600$ nm	$R > 25$
Spectral resolution $\lambda > 600$ nm	$R > 70$
Astrometric precision	< 30 milliarcsec
Fields of view	1 arcmin imager, > 2 arcsec IFS
Mission lifetime	3 years

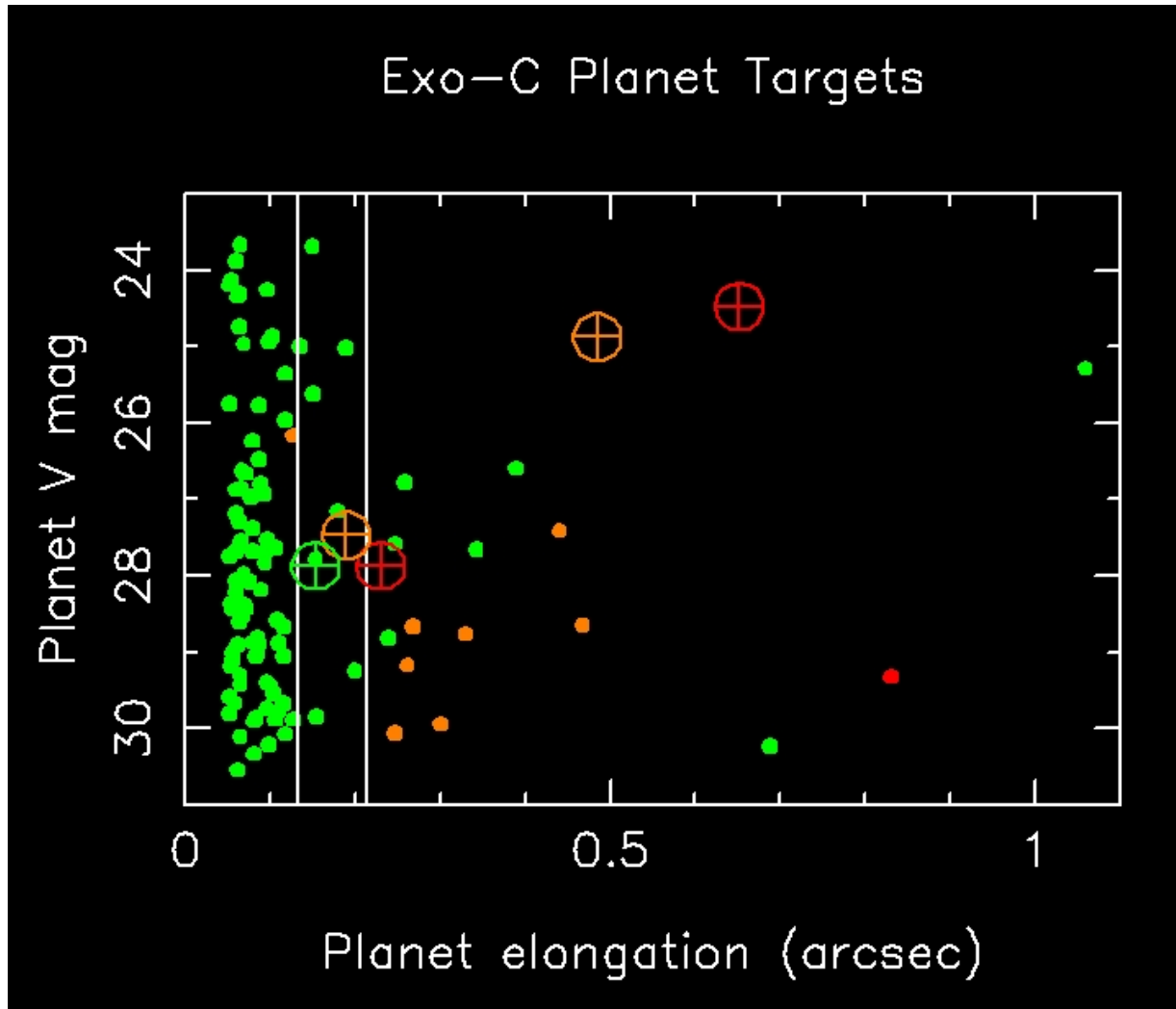

Points are known
RV planets

⊕ Earth analog in
nearby star HZ

Contrast $\geq 1e-9$
 $3e-10 \leq$ Contrast
 $< 1e-9$
 Contrast $< 3e-10$

Vertical lines
show IWA at 500
and 800 nm

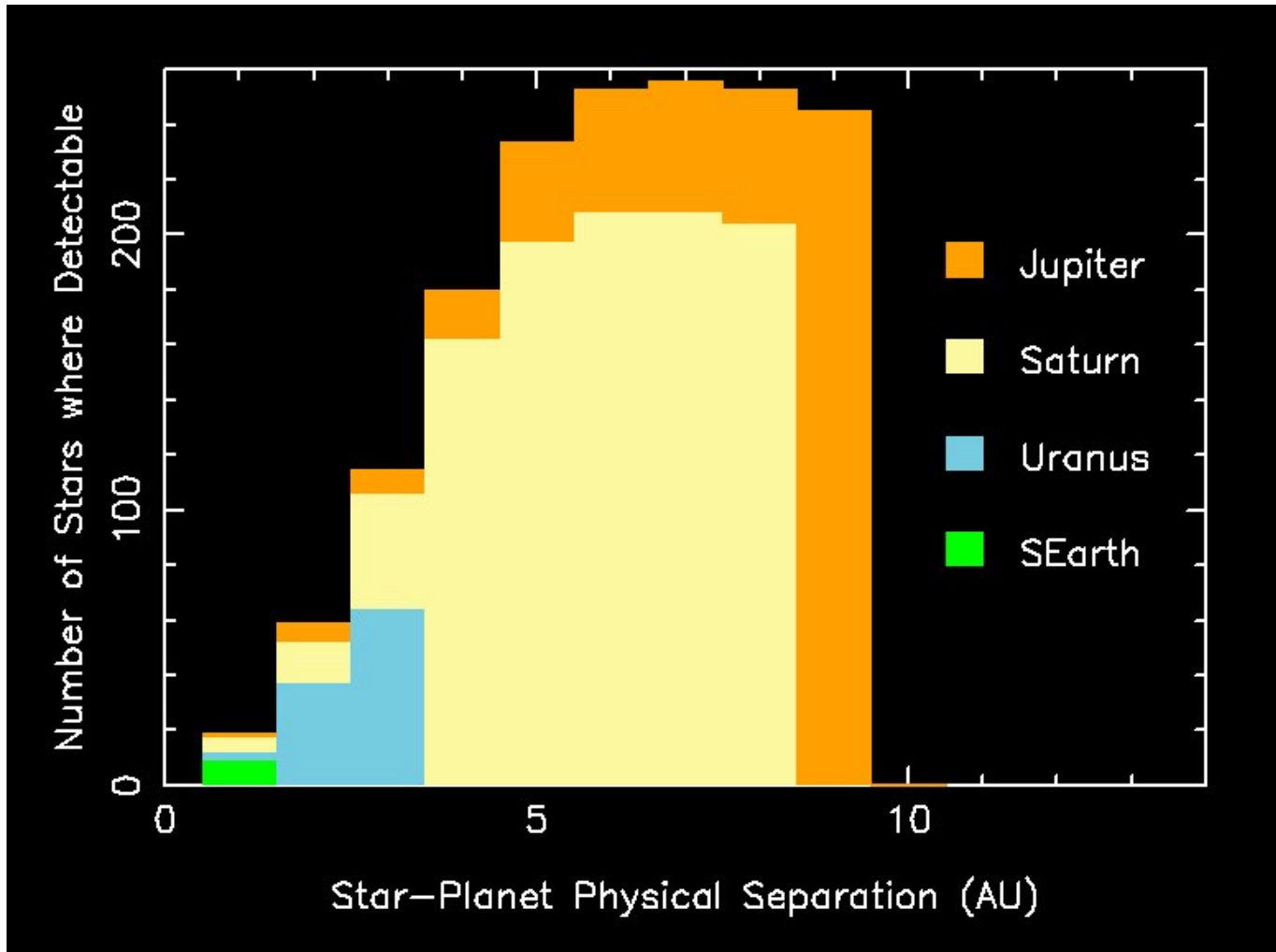

In V band filter in maximum of 10 days integration, 0.75 years total search time

- **Planet characterizations:**
 - Measure spectra of **~20** exoplanets
 - Measure multi-color photometry of an additional **~20** exoplanets
- **Planet discovery surveys:**
 - Survey **20** nearby stars for super-Earths in the HZ
 - Survey **140** nearby stars for giant planets
- **Disk Imaging Surveys:**
 - Deep search for disks in **60** RV planet systems
 - **60** known/resolved debris disks within 40 pc
 - **100** young debris disks from WISE
 - **80** protoplanetary disks in nearby molecular clouds

Below: Simulated 3 hr V band exposure of Altair: Jupiter & Saturn analogs detected, 1 zodi dust ring

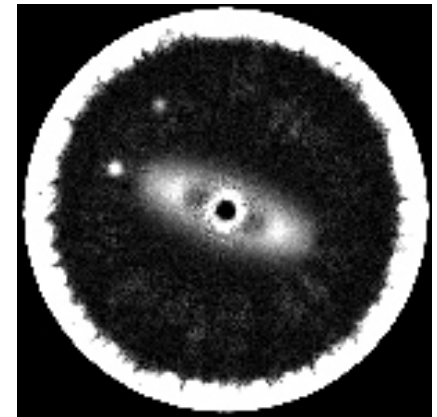

A wide range of science, containing characterizations and surveys

- Highly stable Earth-trailing orbit for three year science mission
- Coronagraphs with $\sim 2 \lambda/D$ inner working angle
- Two stage vibration isolation for science payload
- Bright science target star is used as a reference for precision pointing and compensation of low order wavefront drifts
- Commercial Kepler-like spacecraft bus, Intermediate class launch vehicle

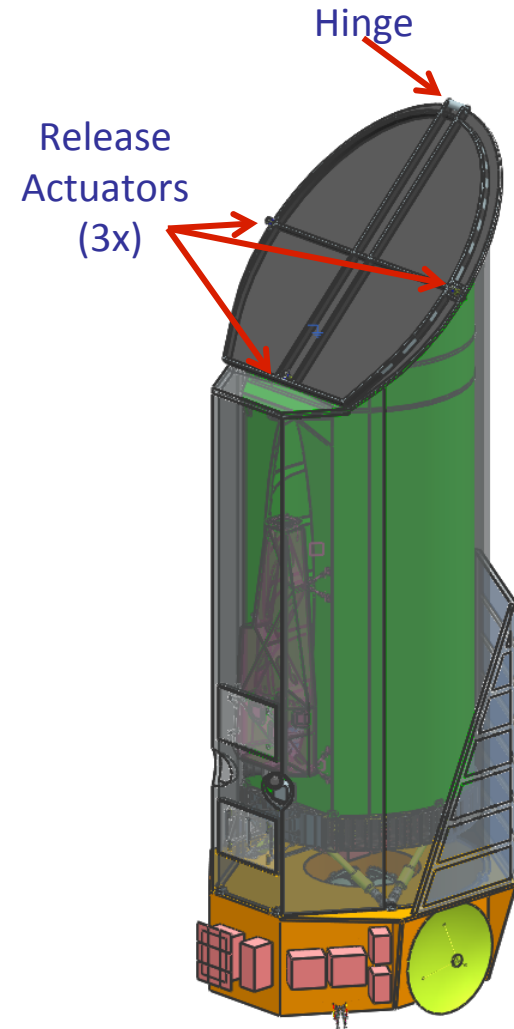

- Unobscured cassegrain telescope with lateral instrument bench configuration
- Telescope aperture has a 1.5m primary with Ultra-Low Expansion glass
- Hybrid Lyot, Vector Vortex, and PIAA coronagraphs carried forward with Integral Field Spectrograph

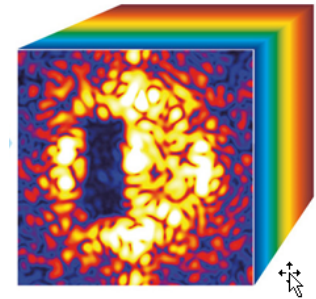
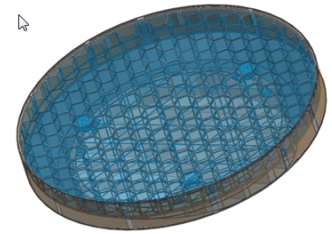
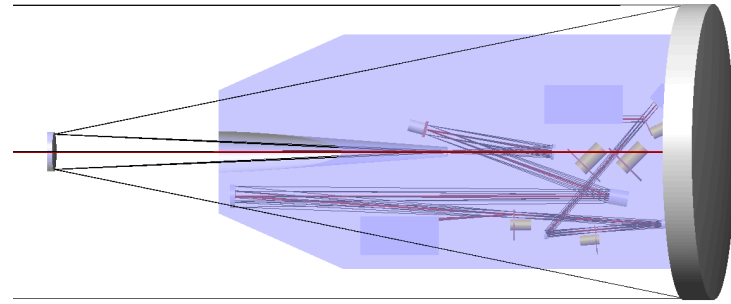

EXTRACTED DATA CUBE

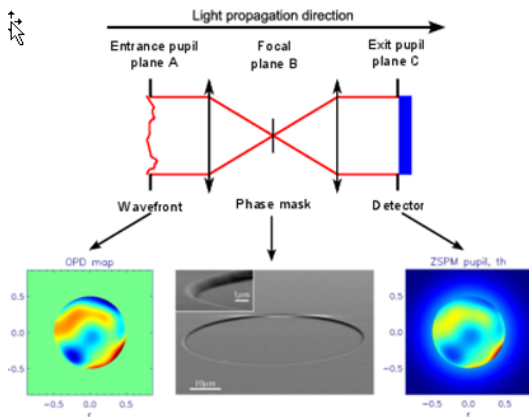

- Zernike Low-Order Wavefront Sensor

Subsystem Description

- Outer Barrel
- Solar Array
- Inner Barrel

- Secondary Mirror
- Instrument Bench
- Primary Mirror
- Primary Support Structure

- PL Avionics
- Radiator Panel
- Star Tracker
- Isolation Struts
- Spacecraft Bus

- SC Avionics
- Antenna
- Thrusters
- LV interface Ring

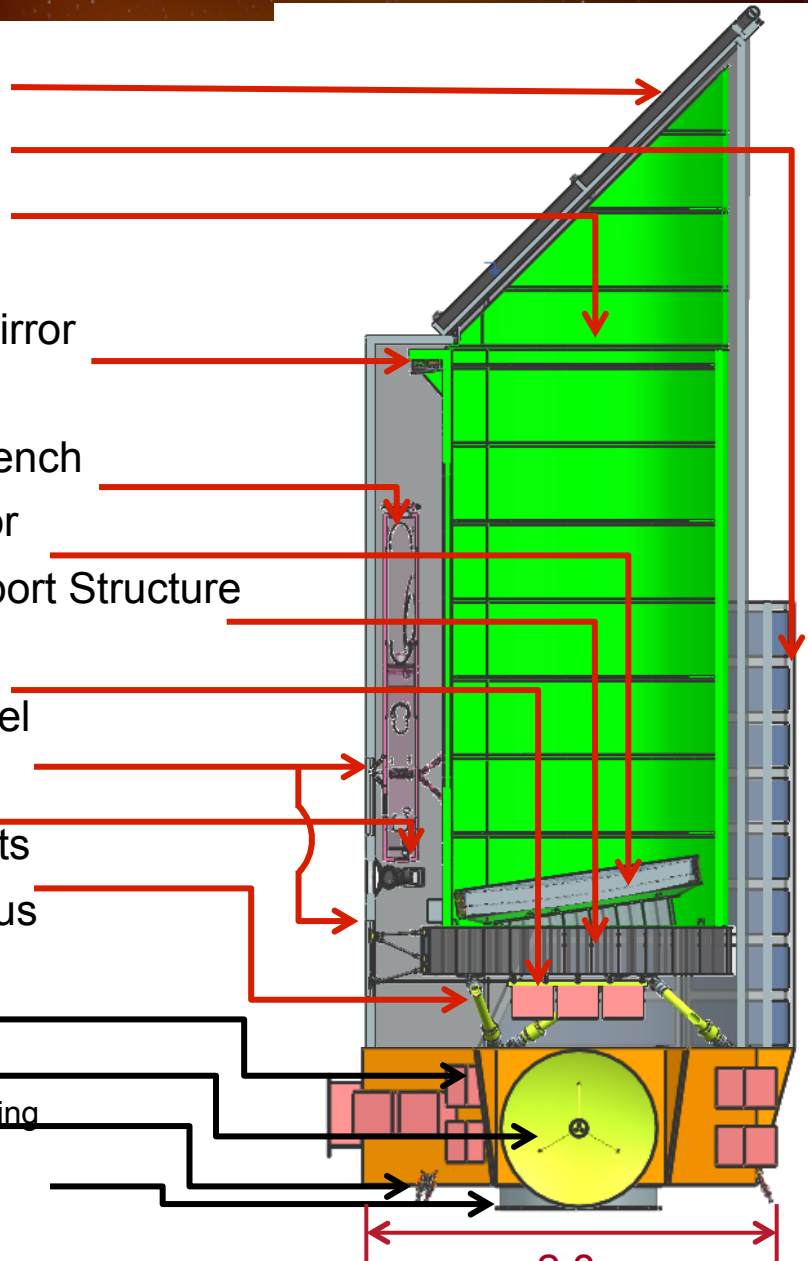

7.6m

2.8m

13_{CAA-13}



Pointing Control System Architecture



A robust pointing architecture that leverages flight proven technologies.

Pointing Requirements	
Telescope Pointing (Angle in the sky, 1 σ RMS)	
Accuracy	1.2 <u>milliarcsec</u> (Line-of-sight tip/tilt)
	10 <u>arcsecs</u> (Line-of-sight roll)
Stability (1000s)	6 <u>milliarcsec*</u> (Line-of-sight tip/tilt)
	10 <u>arcsec</u> (Line-of-sight roll)
Instrument Pointing (Angle in the sky, 1 σ RMS):	
Accuracy	0.08 <u>milliarcsec</u> (Line-of-sight tip/tilt)
Stability (1000s)	0.4 <u>milliarcsec</u> (Line-of-sight tip/tilt)

Key features of the pointing system:	Exo-C	IRIS SmEx (2013)	PICTURE Sounding Rocket (2011)	Kepler Discovery (2009)	Spitzer (2003)	Chandra (1999)	Hubble (1990)	TRACE SmEx (1990)
Fine Guidance Sensor	X	X	X	X	X	X	X	X
High bandwidth Fast Steering Mechanism	X	X	X					X
Enhanced ACS using Fine Guidance Signal	X	X		X		X	X	X
Passive Isolation	X					X	X	
Low Disturbance Earth trailing orbit	X			X	X			
High stiffness observatory (no deployables/articulations)	X			X	X			

- Five architectures were evaluated: Hybrid Lyot, PIAA, shaped pupil, vector vortex, and the visible nuller
- Realistic optical system models for each with wavefront control and telescope pointing errors
- Contrast maps and individual throughputs used to predict science yield for each. Three met science requirements and have path to readiness
- Summary evaluations result in Hybrid Lyot as baseline. Vector Vortex and PIAA remain options for second design cycle

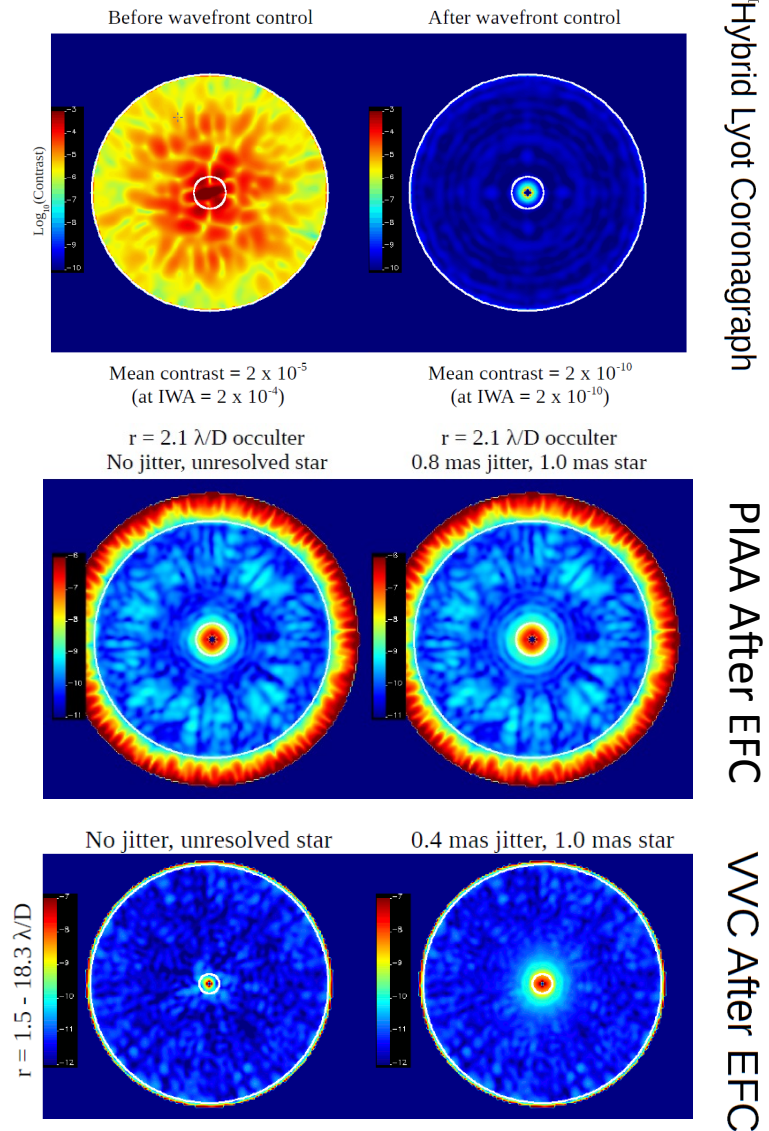

- Currently performing detailed structural analysis on entire payload
- Modal and stress analysis of Inner Barrel with side-mounted instrument bench show material (Composite/Aluminum honeycomb panels) and dimensions are adequate
- **1st mode frequency is 31 Hz**
(rocking of instrument on base)
- Structurally stiffer than typical cassegrain telescope
- Analyses Performed:
 - Normal Modes
 - 10G Quasi-Static
 - Buckling

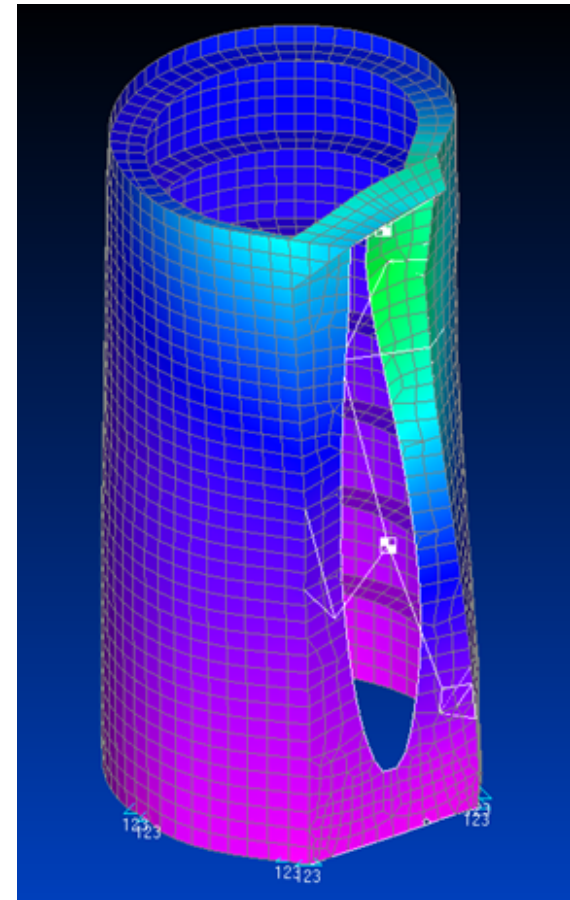

Inner Barrel Finite Element Model with Instrument Bench Point Mass and Bipods

- Results of 45 degree pitch maneuver

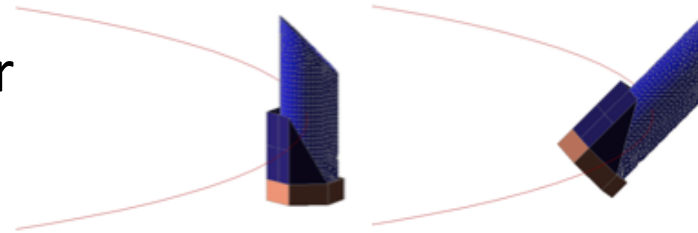

Primary mirror (active thermal control) changes less than

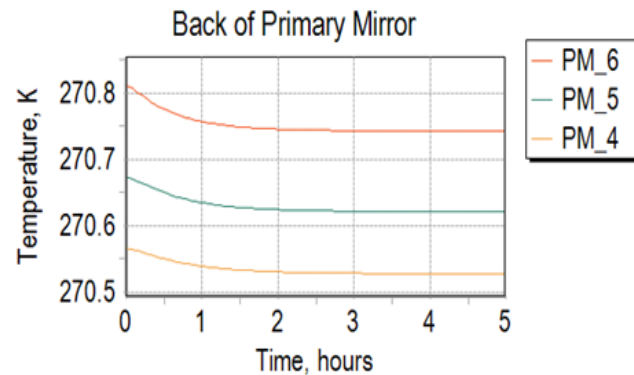
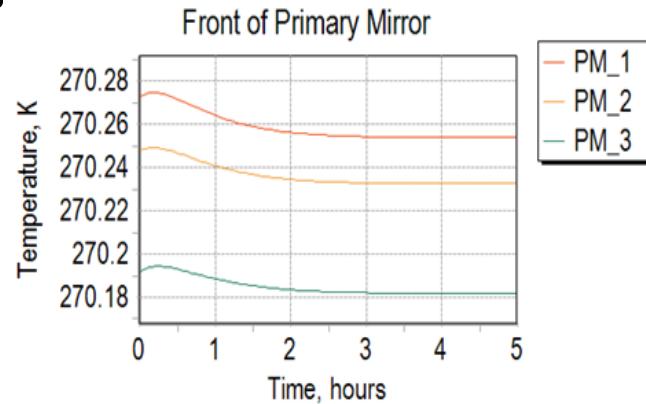
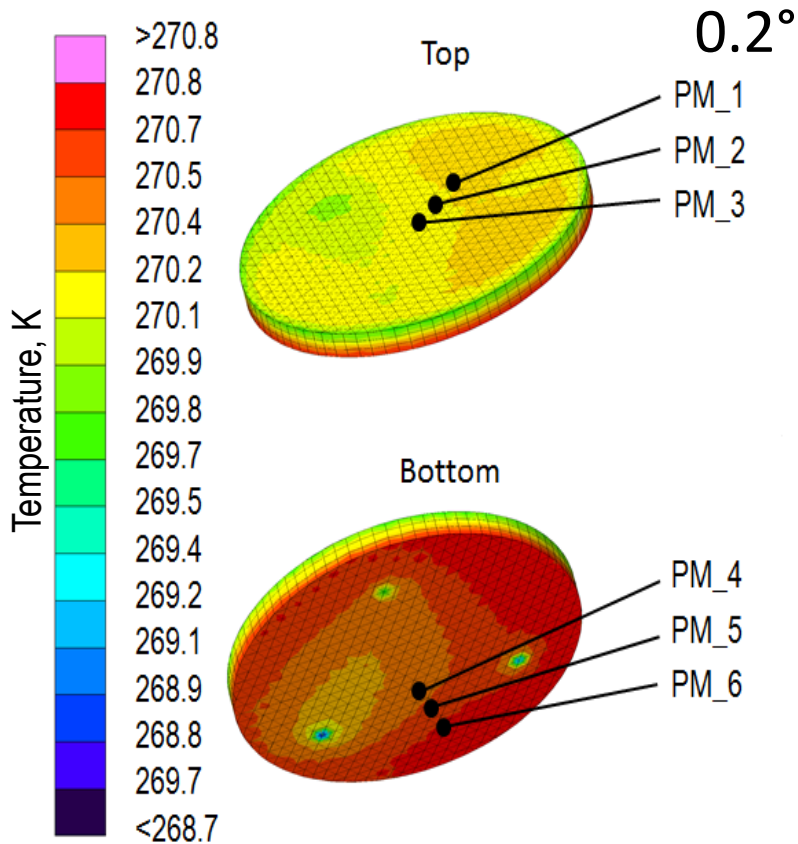

Telescope Transient from 45° Pitch Maneuver

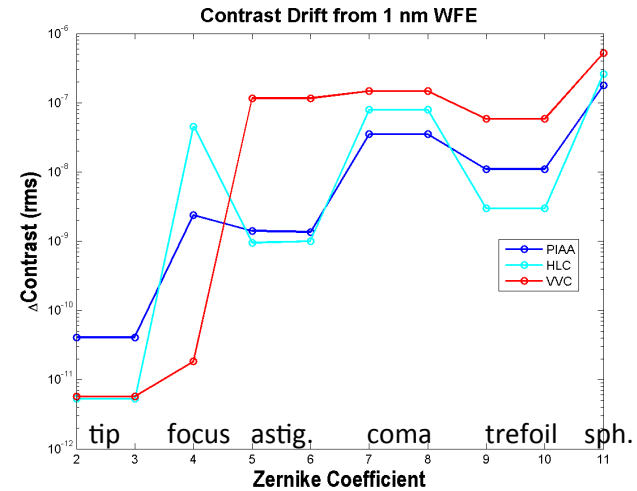
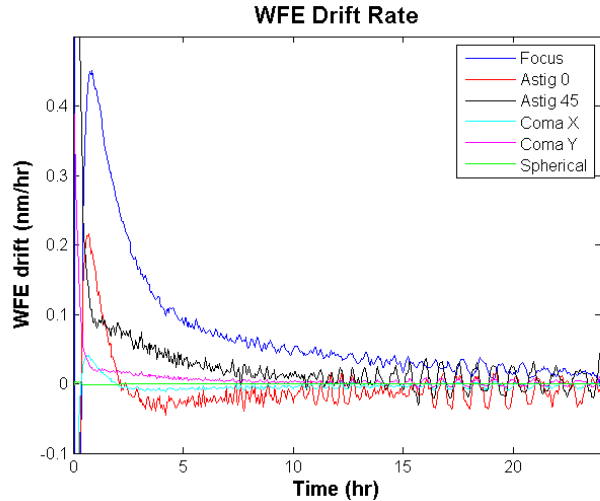
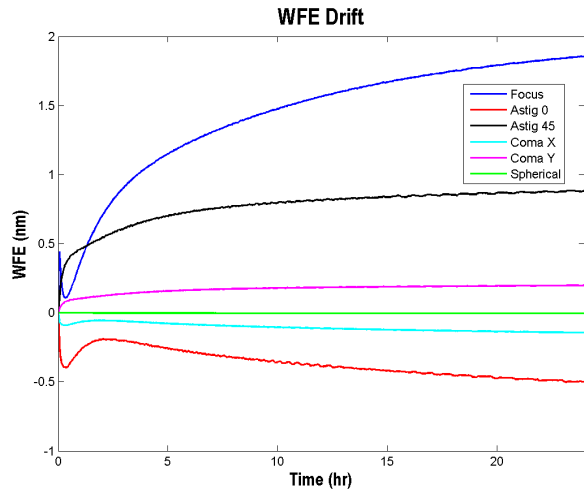

- WF drift does not stress DM stroke or Low Order WaveFront Sensor (LOWFS) capture range.
- Slow wavefront drift rate reduces demands on LOWFS bandwidth.
- Only focus and astigmatism significantly contribute to contrast drift after about 5 hours. ($\Delta\text{Contrast} \propto \text{WFE}^2$).

Thermal-mechanical design reduces drift to an easily manageable level.

- Exo-C bandwidth & contrast specs already met by Hybrid Lyot coronagraph; $2 \lambda/D$ inner working angle requirement met by PIAA & Vortex coronagraphs
- Need to demonstrate all the above in a single instrument in the presence of dynamic pointing & wavefront errors → Low-order wavefront control.
- Exo-C technology is built on years of TPF & TDEM investments and is closely aligned with planned AFTA coronagraph investments and demonstrations.

48x48 Xinetics deformable mirror has been shake tested

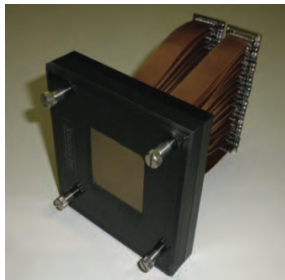

HCIT Lab contrast demonstration

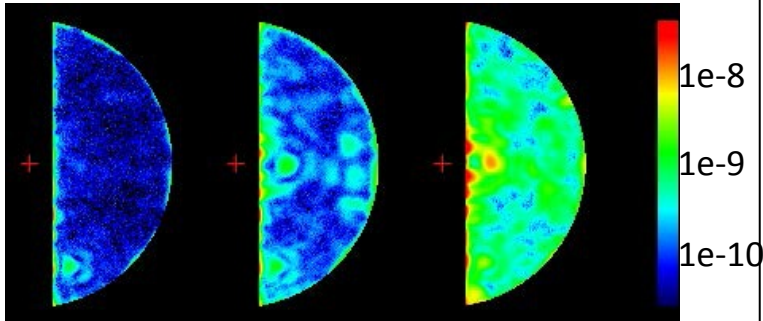

JPL High Contrast Imaging Testbed

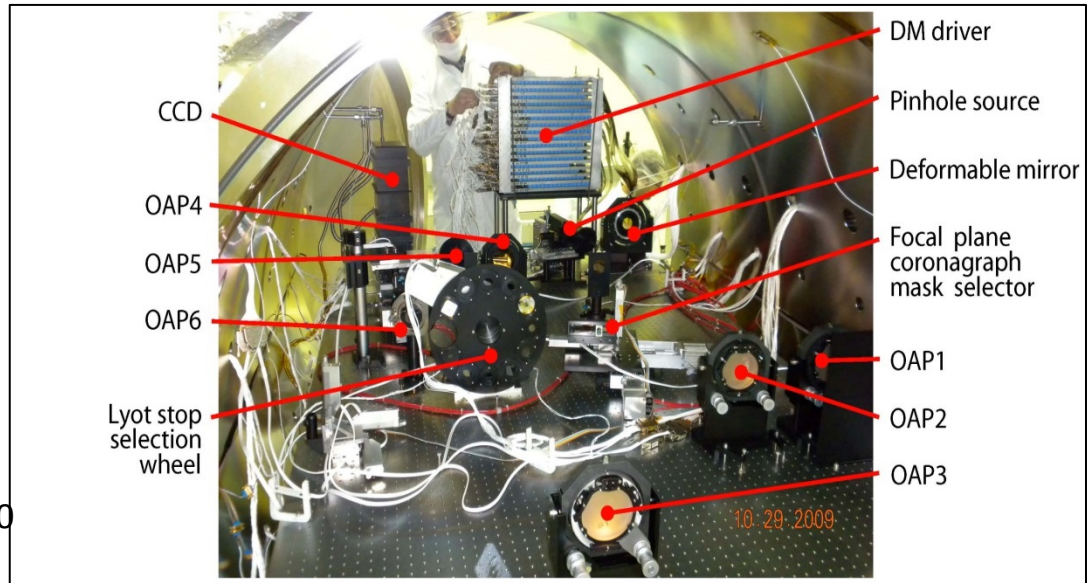

EXO-C Design Team preliminary cost estimate is less than the \$1B Charter requirement

- Over 80% of the pre-reserve estimate comes from objective models and Kepler actual costs:
 - Instrument cost: NASA Instrument Cost Model v5 (NICM)
 - Telescope cost: Luedtke and Stahl model
 - published in SPIE's *Optical Engineering* in 2012 and 2013
 - Science, ground system, operations and most of the spacecraft costs came from Kepler actual costs
 - Kepler is the best analogue because it has:
 - a 1.4m primary telescope
 - same orbit and planned mission life
 - same s/c design (except for 2-stage passive isolation hardware)
 - same ground system design
 - and similarly focused exoplanet science.
- Kepler ~\$700M (FY15) through first 3 years on orbit
- Exo-C adds 30% reserve on top of these estimates
- Plan to iterate CATE
 - ExEP Study Office has a task with the Aerospace CATE team for 3 estimates over the next year
 - The Design Team is holding meetings with the CATE team to review key design issues in detail

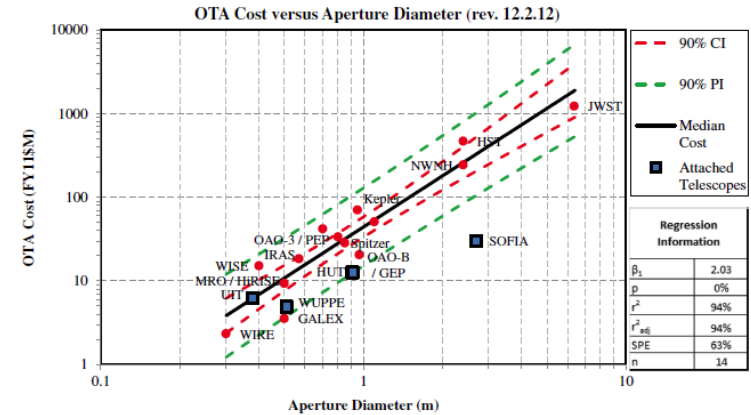

Telescope cost as a function of aperture diameter for space-based telescopes (Figure credit: SPIE)

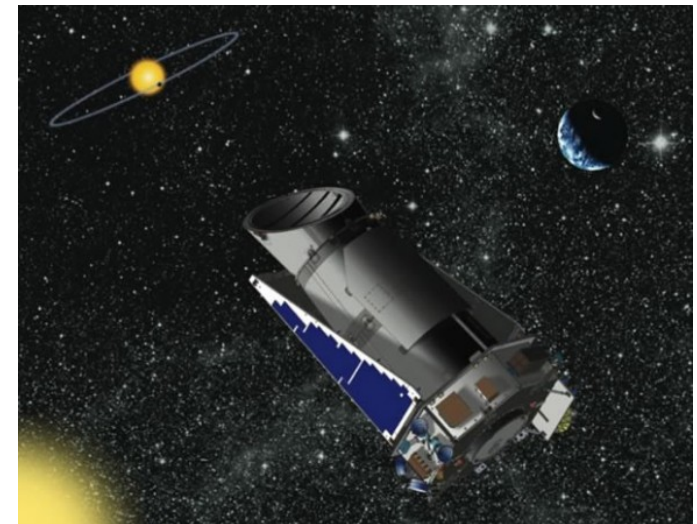

Artist concept of the Kepler spacecraft (Image credit: NASA)

- Detailed modeling of pointing control loop and beam walk effects on achieved contrast
- Extend performance analysis of the three coronagraph architectures to include telescope dynamics and low order wavefront control
- Assessment of spacecraft stability lessons learned from Kepler
- Submit Cost And Technical Evaluation inputs to Aerospace Corp. and respond with design changes if necessary (late spring 2014).

Evaluate performance, cost, risk.

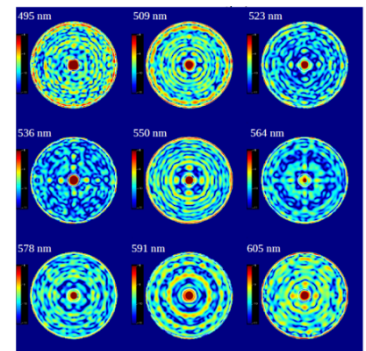
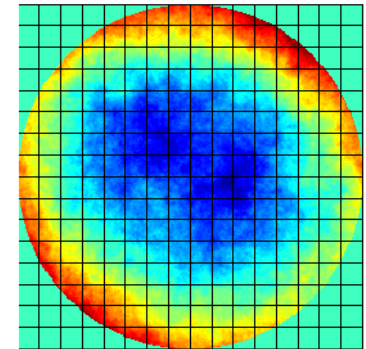
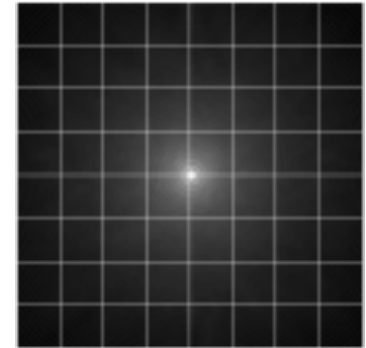

Key take away points

- Exo-C uses an internal coronagraph with precision wavefront control to conduct high contrast imaging at visible wavelengths
- Exo-C's science goals are to:
 - Spectrally characterize at least a dozen RV planets
 - Search >100 nearby stars at multiple epochs for planets down to $\sim 3 \times 10^{-10}$ contrast. Characterize mini-Neptunes, search the α Centauri system.
 - Image hundreds of circumstellar disks
- A baseline design is in place and will continue to be refined in 2014. Exo-C's aperture, orbit, spacecraft, & lifetime are very similar to those of the Kepler mission, which is our cost reference
- Exo-C is a technology pathfinder for a future New Worlds mission

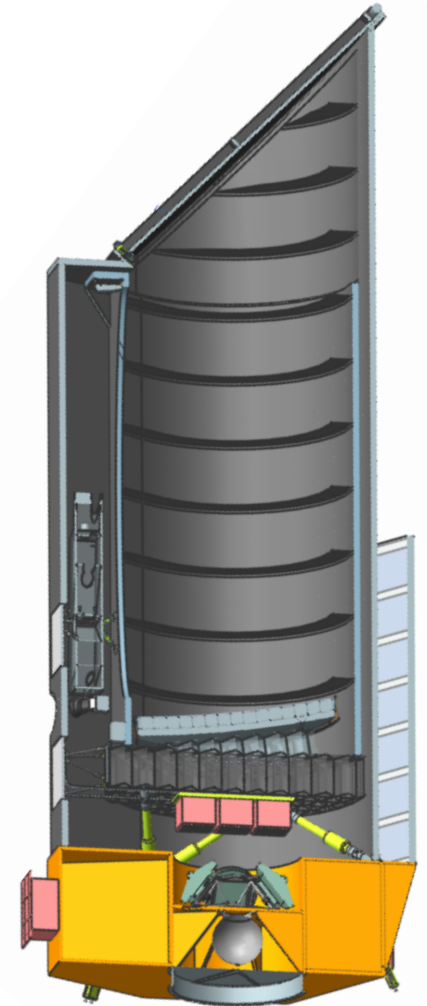

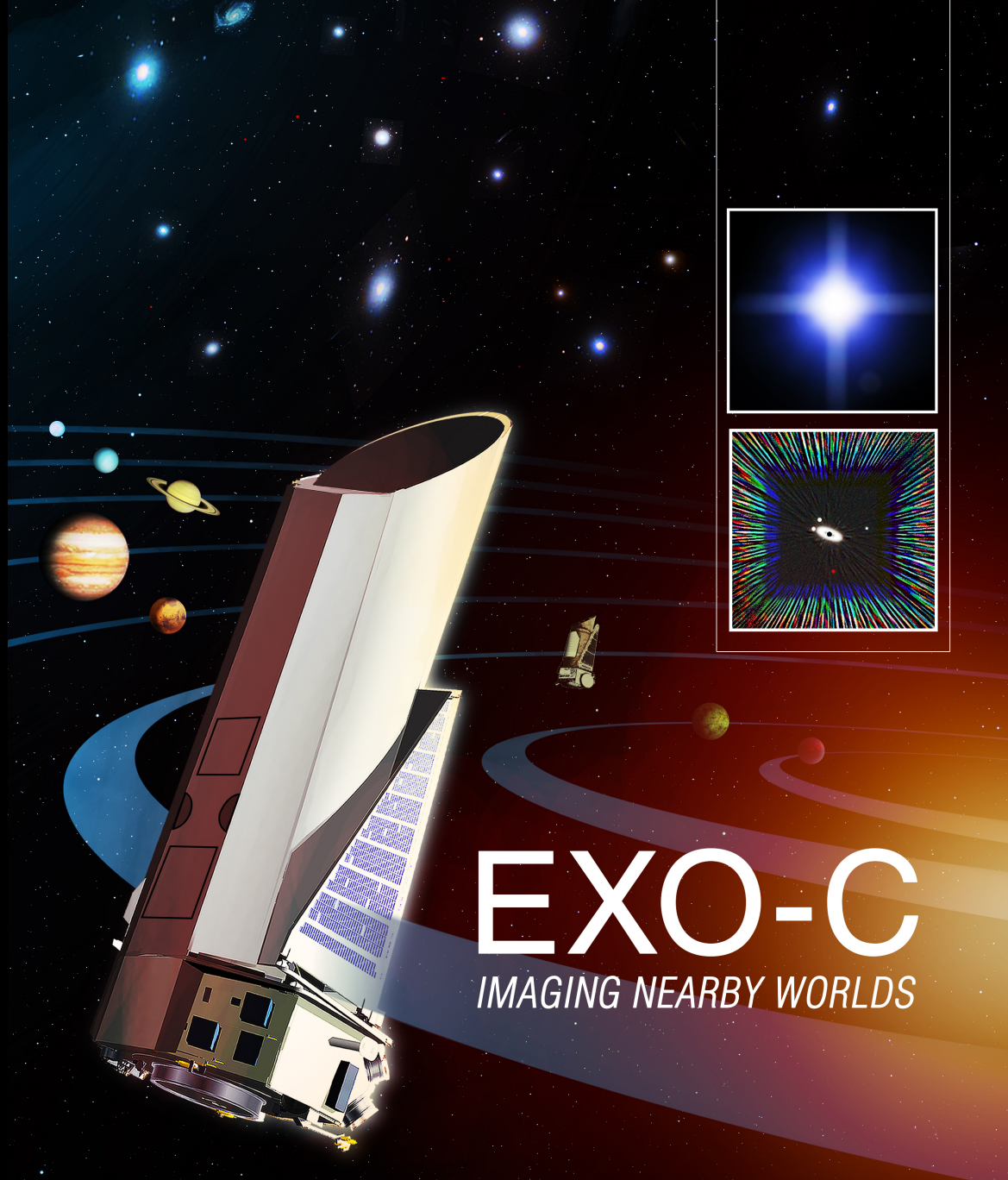

EXO-C

IMAGING NEARBY WORLDS



BACKUP



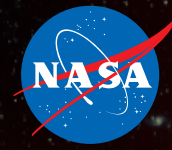

- New strategic mission expected to start in FY17. It will be AFTA/ WFIRST if budget allows. If not, need less expensive “probe” mission options as backups. Three to choose from: WFIRST, and 2 exoplanet.
- Probe mission terms:
 - Cost ~ \$1B
 - Technical readiness (TRL 5) by 2017
 - Launch in 2024
- Exo-C is an 18 month HQ-funded study of an internal coronagraph probe mission
 - Science & Technology Definition Team (STDT) selected May 2013. *Previous competitors now working together.*
 - Engineering Design Team in place at JPL, July 2013
 - Interim report for March 2014; final report due January 2015

Accessible RV Planets vs. Aperture Size

Known RV planets vs. $2 \lambda/D$ @ $\lambda = 0.8 \mu\text{m}$

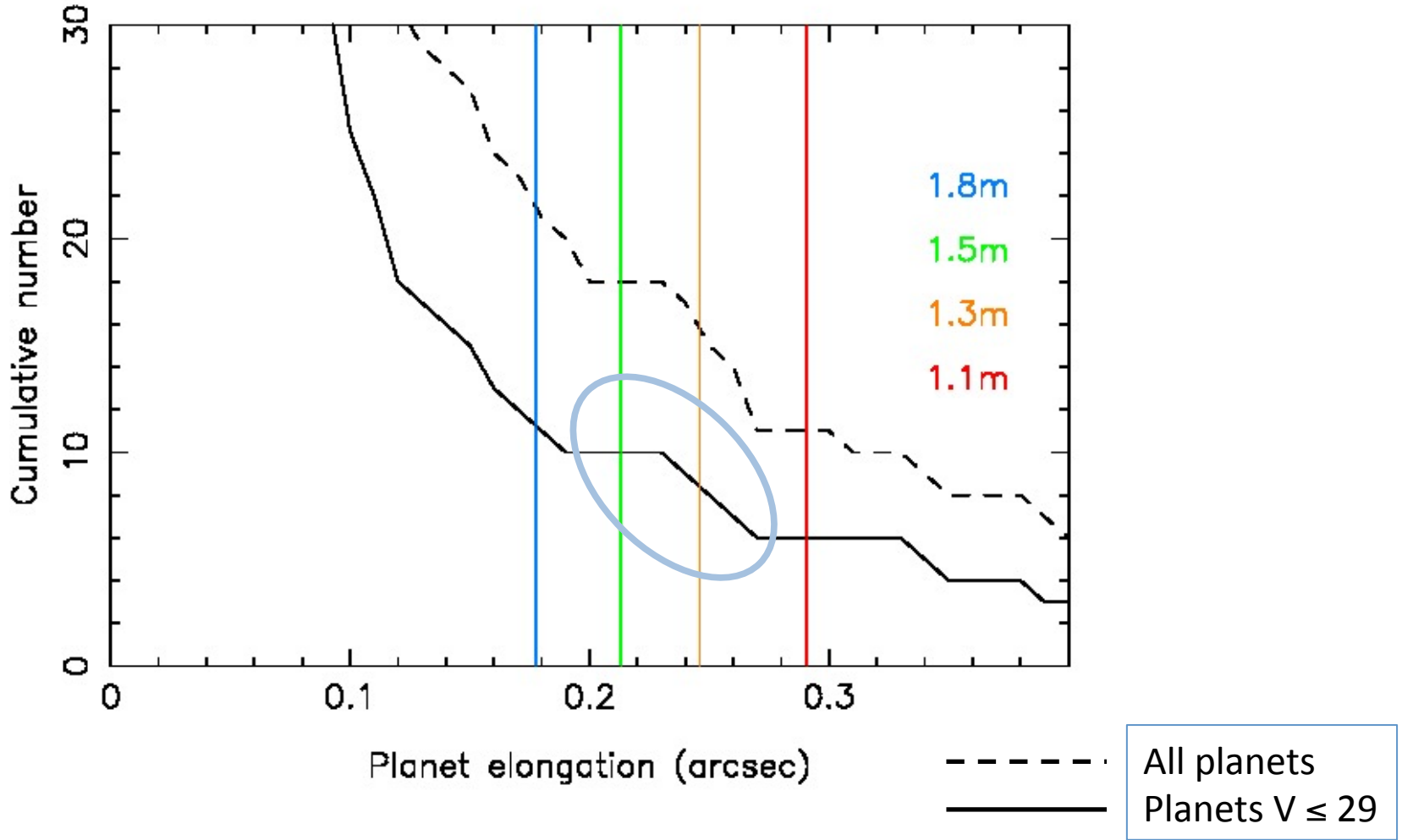

α Centauri Orbit sets stray light requirement

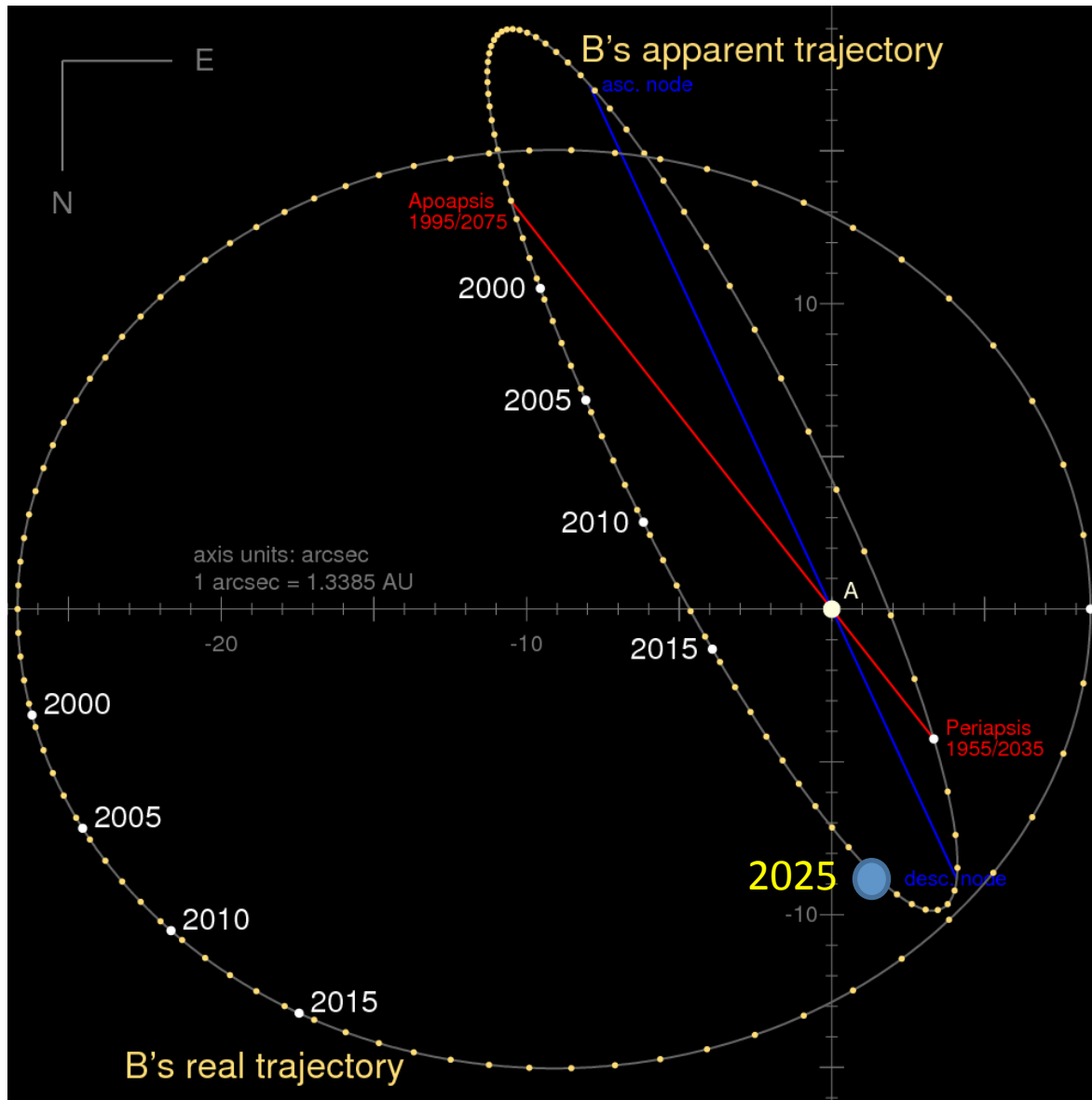

8.5" separation in 2025, increasing to 10.5" in 2028. CONTROL OF SPILLOVER LIGHT:

- Coronagraph mask concepts to block both stars and accommodate the variable separation
- Primary mirror surface quality specifications at 100 cycles/aperture
- Agile dark hole using deformable mirrors
- Careful baffling and control of internal reflections



Preliminary DRM / expected science yield



Science Type	Visits		Science Observation		Total Mission Time	Observation efficiency
	No. of targets	Ave No. of visits	Average Integration time per visit	Total Observe time per Science		
	N_target	N_visit	t_I	T_Obs	T_M	T_Obs/T_M
			(hrs)	(days)	(days)	
Planet characterizations						
Spectroscopy of Known Exoplanets (known from RV, AO, and exo-C survey)	20	1	200	167	193	87%
Multi color photometry of Known Exoplanets (known from RV, AO, and exo-C survey)	20	1	20	17	43	39%
Planet discovery surveys						
Survey nearby stars for super-Earths within the habitable zone	20	6	20	100	150	67%
Search for giant planets around nearby stars	140	3	20	350	525	67%
Disk Imaging Surveys						
Detection survey in RV planet systems	60	1	12	30	40	75%
Known debris disks within 40 pc	60	1	6	15	24	63%
Young debris disks from WISE	100	1	6	25	40	63%
Nearby protoplanetary disks	80	1	6	20	32	63%
Total on-orbit ops time				723	1045	
Initial On-Orbit Checkout (days)					60	
Total (days)					1105	65%
Total (years)					3.0	



General Astrophysics Capability



- High contrast science on post-main sequence stars, AGN/quasars, ...
- Imaging camera will have 1 arcmin FOV with small filter set; IFS will have $\sim 2''$ FOV
- Camera and IFS could be used without coronagraphic spots
- Pointing performance for targets other than bright stars is still TBD. Support for moving targets conceivable but not in baseline cost.
- Not currently planning for UV capability (cost)
- A second instrument could be accommodated in terms of payload mass/volume, but not in terms of cost



Exo-C Design Trades Completed



Trade	Outcome
Telescope obscured vs. non-obscured	Unobscured aka "off-axis"
Telescope design	Cassegrain
Telescope material: Glass vs. silicon carbide (SiC)	Ultra-Low Expansion (ULE) glass
Orbit	Earth-training
Aperture size	1.5 m
High-gain antenna (HGA)	Fixed
Isolators: between reaction wheel assembly (RWA) and spacecraft, and again between spacecraft and payload	Two passive layers
Deformable mirrors	Two 48 × 48
Instrument configuration: Lateral vs. behind primary mirror	Lateral
Mission design	Baseline configuration in §6
Low-order wavefront sensor (LOWFS) design	Zernike WFS, spectral splitting
Spacecraft bus	Kepler type
Solar array configuration	Fixed
Mission lifetime	3 years, consumables for 5 years
Pointing architecture	Isolation, flight management system (FMS), payload, and spacecraft interface
Spectrometer architecture	Integrated field spectrometer (IFS): details of design pending (# of lenslets, spectral resolution, detector)
Telescope stability—thermal architecture	Inner barrel w/ heater control, outer barrel, and primary mirror heater control
Secondary mirror configuration	Actuated secondary
Telescope metering structure configuration	Integrated with inner barrel assembly
Instrument architecture	Coronagraph, imaging camera, IFS, fine-guidance sensor (FGS),
Coronagraph architecture – Step 1 completed	Hybrid Lyot, Vector Vortex, and PIAA carried forward for second trade analysis



Pointing System Block Diagram

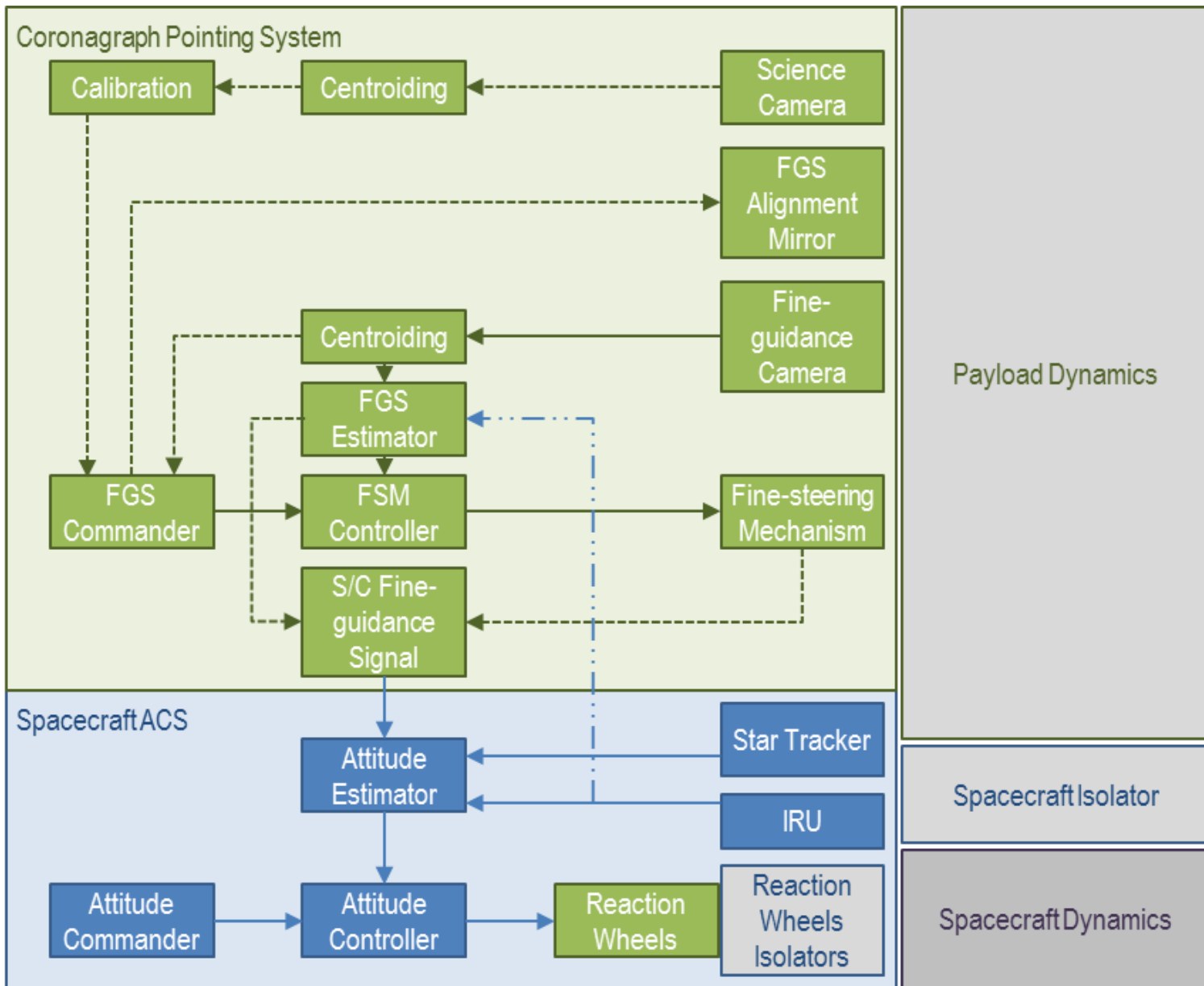



Preliminary Schedule



STDT-Coronagraph Top Level (Preliminary Schedule)

Rev. 1/15/2014

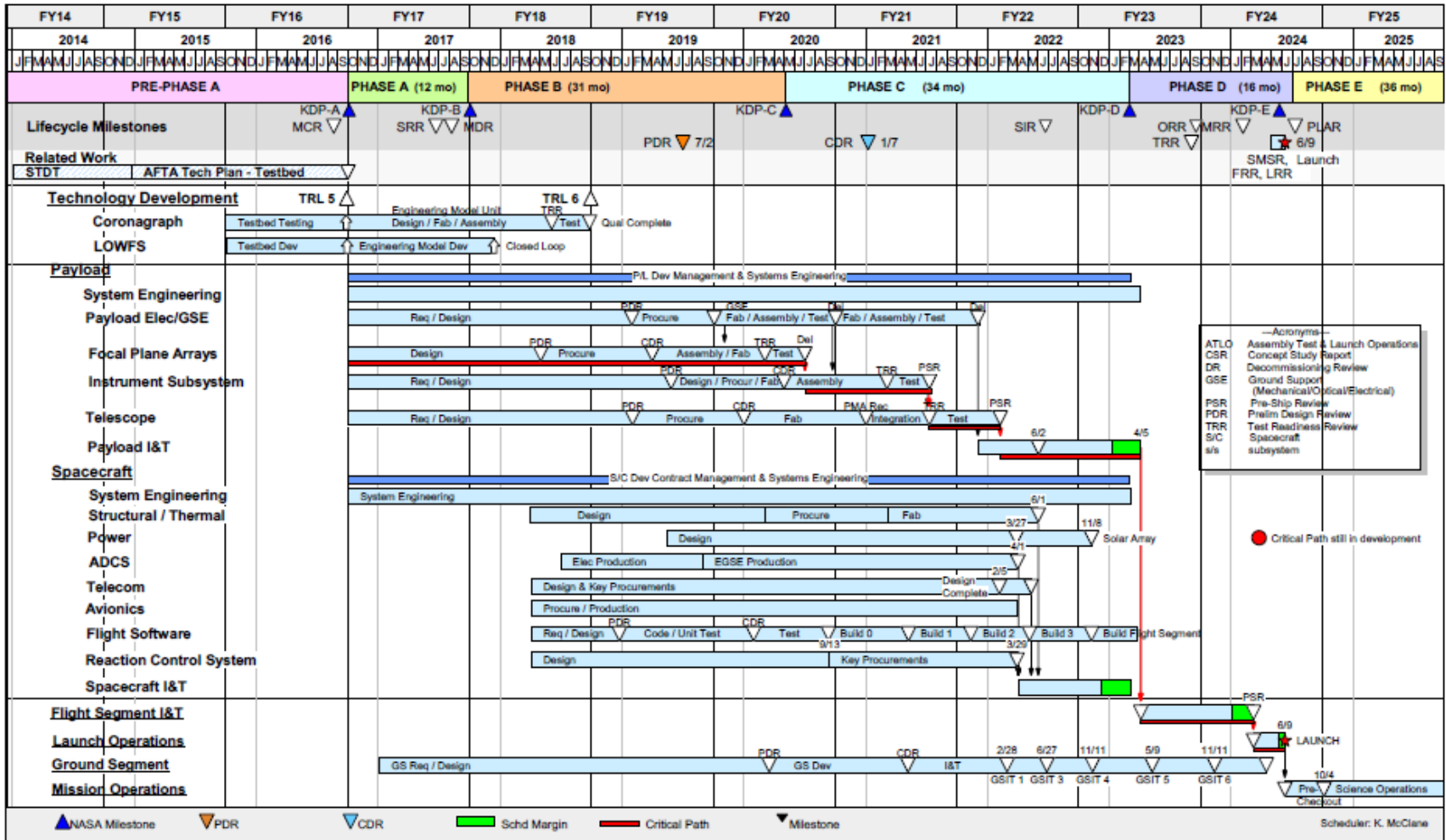

Probe studies are directed to be based on a Phase A start at the beginning of FY17, project PDR in FY19 and a launch no later than 12/31/2024. The schedules includes funded schedule reserves per JPL Design Principles.